



Assembly Precautions for the Nichia 088 Series LEDs

Table of contents

1.	<u>LED Outline Dimensions/Tape and Reel Dimensions</u>	· · · · ·	2
2.	<u>Handling Precautions</u>	· · · · ·	3
3.	<u>Design Recommendations for Optimal Amount of Solder</u>	· · · · ·	4
4.	<u>Precautions for Setting Up a Pick-and-Place Machine/Nozzle</u>	· · ·	5-9
5.	<u>Precautions When Reflow Soldering</u>	· · · · ·	9

NSSW088A and NSSW088B refer to Nichia part numbers. These Nichia part numbers within this document are merely Nichia’s part numbers for those Nichia products and are not related nor bear resemblance to any other company’s product that might bear a trademark.

This document contains tentative information, Nichia may change the contents without notice.

1. LED Outline Dimensions/Tape and Reel Dimensions

Table 1. NSSx088x Product Specifications

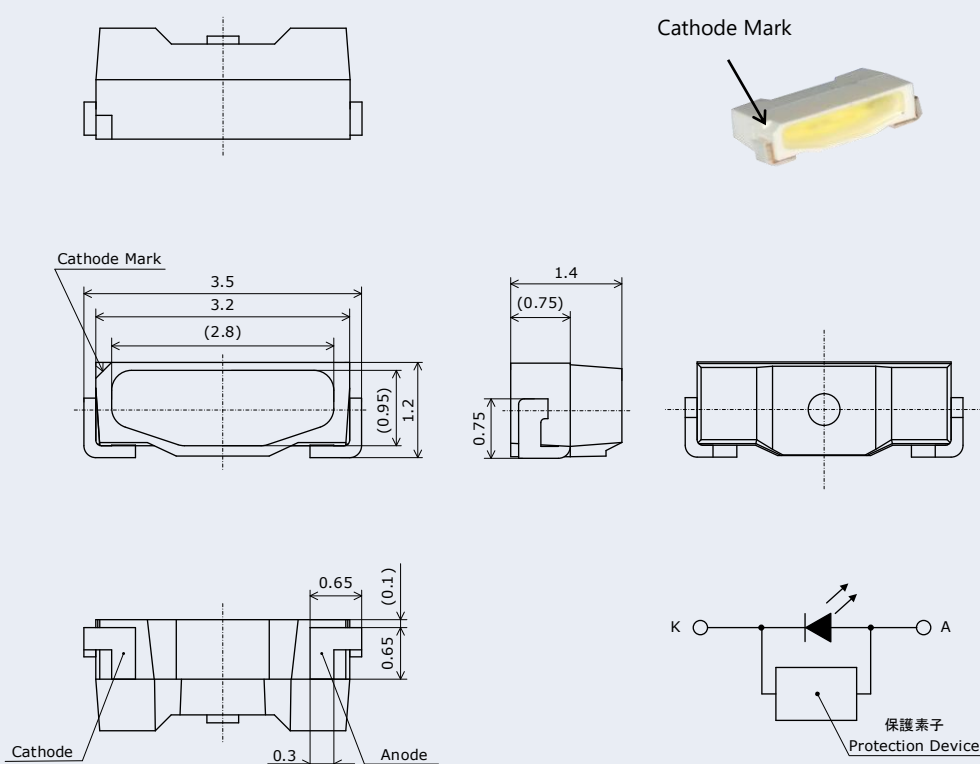
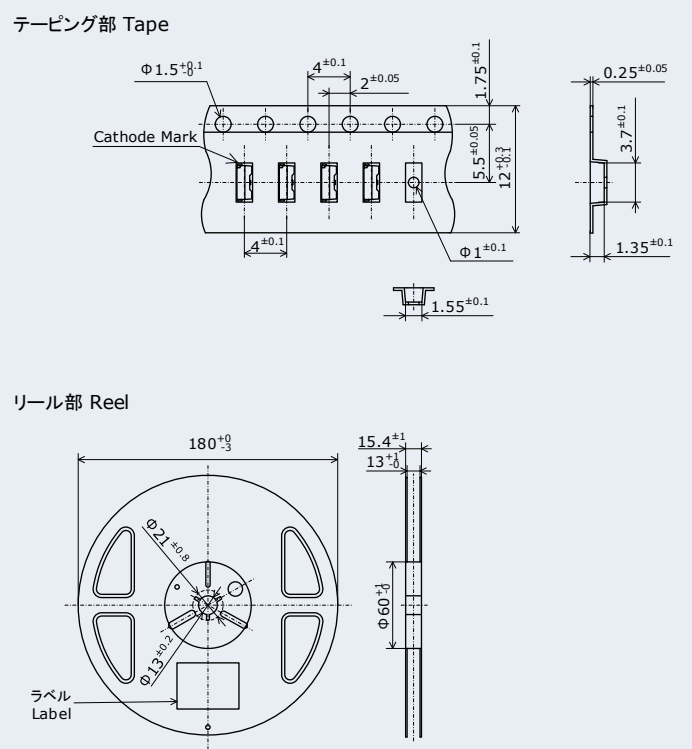
LED	Embossed Carrier Tape
 <p> Cathode Mark Cathode Anode 保護素子 Protection Device Weight: typ. 0.010g (Unit: mm, Tolerance: ±0.1mm) </p>	 <p> テーピング部 Tape リール部 Reel Reel Size: 3,000 LEDs (Unit: mm) </p>

The weight value provided in Table 1 is the weight for the NSSW088A LED.

This document contains tentative information, Nichia may change the contents without notice.

2. Handling Precautions

2-1. Handling with Bare Hands

Do not handle the LEDs with bare hands:

- this may contaminate the LED surface and have an effect on the optical characteristics,
- this may cause the LED to deform and/or the wire to break causing a catastrophic failure (i.e. the LED not to illuminate),

2-2. Handling with Tweezers

Ensure that when handling the LEDs with tweezers, excessive force is not applied to the LED. Otherwise, it may cause damage to the resin (e.g. cut, scratch, chip, crack, delamination and deformation) and/or the wire to break causing a catastrophic failure.

2-3. ESD Precautions

The LEDs are sensitive to transient excessive voltages (e.g. ESD, lightning surge). If this excessive voltage occurs in the circuit, it may cause the LED to be damaged causing issues (e.g. the LED to become dimmer or not to illuminate [i.e. catastrophic failure]). When handling the LEDs, ensure that necessary measures have been taken to protect them from transient excess voltages. Refer to the applicable specification for more details.

2-4. Stacking Assembled PCBs Together

Do not stack assembled PCBs together. Otherwise, it may cause damage to the resin (e.g. cut, scratch, chip, crack, delamination and deformation) and the wire to break causing a catastrophic failure.

2-5. Baking

The NSSW088A LED is comparable to JEDEC Moisture Sensitivity Level (MSL) 3 or equivalent and the NSSW088B LED is comparable to MSL2 or equivalent. Refer to IPC/JEDEC STD-020 for detailed information regarding the MSL. When baking the LEDs, remove the reel of the LEDs from the moisture-proof aluminum bag.

Table 2. Storage/Baking Conditions

	Conditions	Temperature	Humidity	Time
Storage	Before Opening the Moisture-proof Aluminum Bag	≤30°C	≤90%RH	Within 1 Year from Delivery Date
	After Opening the Moisture-proof Aluminum Bag	≤30°C	≤70%RH	MSL3: Within 168 Hours MSL2: Within 1 Year
	Baking	65±5°C	-	MSL3: ≥24 Hours

✓ Correct

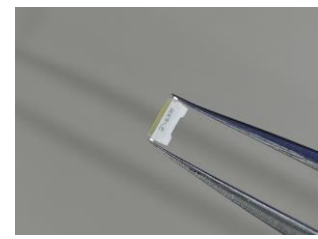

⊘ Incorrect

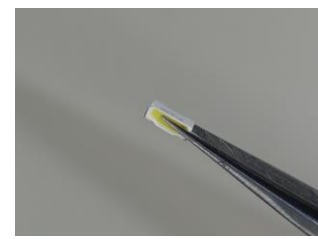

⊘ Incorrect

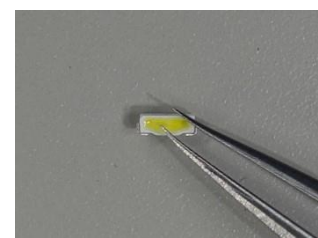

Figure 1. Correct/Incorrect Examples of Handling with Tweezers

This document contains tentative information, Nichia may change the contents without notice.

3. Design Recommendations for Optimal Amount of Solder

Soldering Pad Pattern/Metal Solder Stencil Aperture

Table 3. Recommended Soldering Pad Pattern/Metal Solder Stencil Aperture

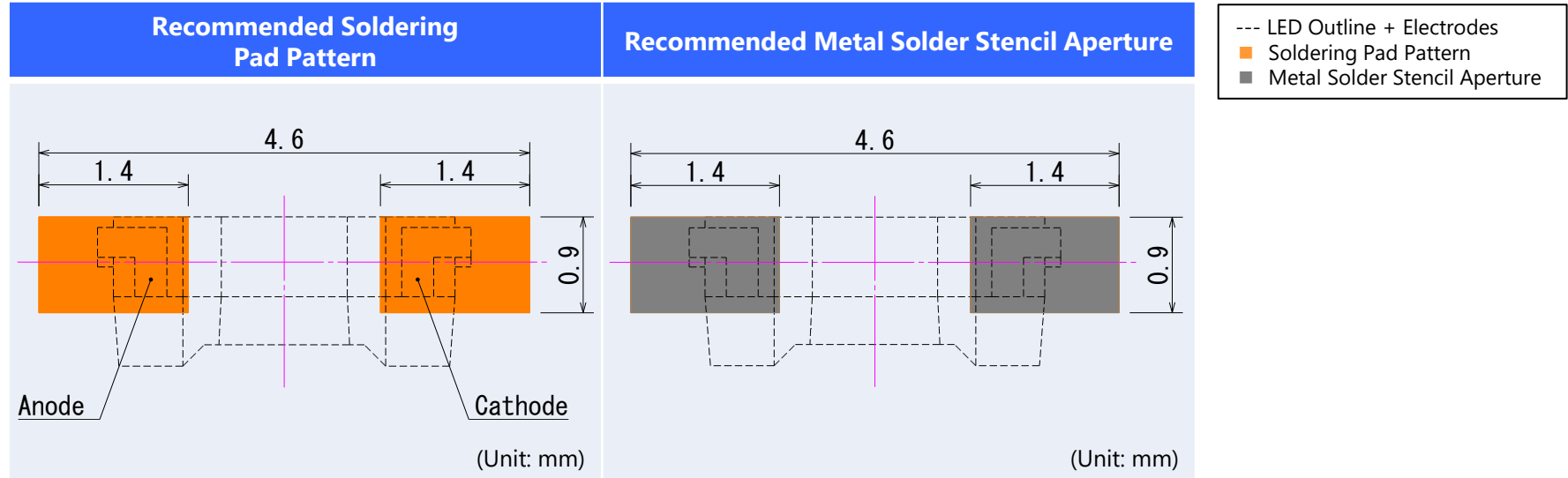

Table 4. Recommended Solder/Metal Solder Stencil Conditions

Item	Recommended Conditions
Metal Solder Stencil (Thickness)	150μm
Solder Paste (Composition)	Sn-3.0Ag-0.5Cu

The recommended soldering pad pattern, metal solder stencil aperture, and thickness of the metal solder stencil provided in Tables 3 and 4 have been determined under Nichia’s conditions: ensure that there are no issues with the chosen assembly conditions prior to use.

4. Precautions for Setting Up a Pick-and-Place Machine/Nozzle

Table 5. Cautions/Suggestions for Setting Up Equipment

Item	Recommended Conditions/Specifications	Cautions/Suggestions
Pick-and-Place Machine	Modular mounter	The recommended conditions/specifications herein have been determined using YS100 High-Speed General-Purpose Modular (manufactured by Yamaha Motor Co., Ltd.).
Pick-and-Place Nozzle	Use a nozzle that is appropriate for the dimensions of the LED.	See "4-1. Pick-and-Place Nozzle" on Page 6 for details.
Tape-and-Reel Feeder	Electrical (motorized) feeder Tape width: 12mm Feeder pitch: 4mm	See "4-2. Tape-and-Reel Feeder" on Page 7 for details.
Top Cover Tape Removal Position	Sufficiently far away from the LED pick-up position.	See "4-2. Tape-and-Reel Feeder" on Page 7 for details.
Nozzle Height for Pick-up Operations	The contact surface of the nozzle head for pick operations should be adjusted to 0.15mm below the edge of the embossed carrier tape pocket.	See "4-3. Recommended Nozzle Height for Pick-up Operations" on Page 8 for details.
Nozzle Height for Placement Operations (i.e. Placement Depth)	0.2mm for placement depth	See "4-4. Recommended Nozzle Height for Placement Operations (Placement Depth)" on Page 8 for details.
Imaging-based Automatic Inspection	Using the electrode as a reference is recommended to locate the center of the LED.	See "4-5. Imaging-based Automatic Inspection" on Page 9 for details.

This document contains tentative information, Nichia may change the contents without notice.

4-1. Pick-and-Place Nozzle

1. Pick up the LEDs at the flat area of the LED; do not pick up the LEDs at the sloped area (see Figure 2).

✓ Correct

Pick up the LEDs at the flat area.

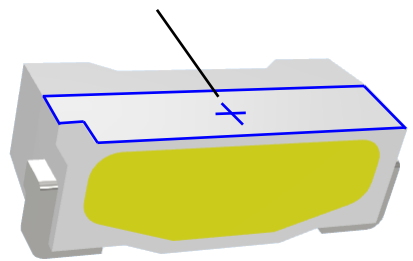

Incorrect

Do not pick up the LEDs at the sloped area.

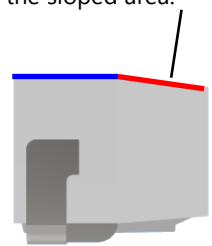
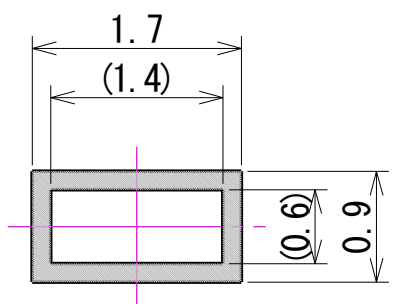

Figure 2. Correct/Incorrect LED Pick-up Position

2. Use a nozzle that is appropriate for the LED (i.e. the nozzle dimensions are appropriate for the dimensions of the recommended pick-up position for the LED). Figure 3 shows an example of a recommended nozzle tip.



(Unit: mm)

Figure 3. Example of a Recommended Nozzle Tip

3. Figure 4 shows the pick-up position for the LEDs in the embossed carrier tape pocket.

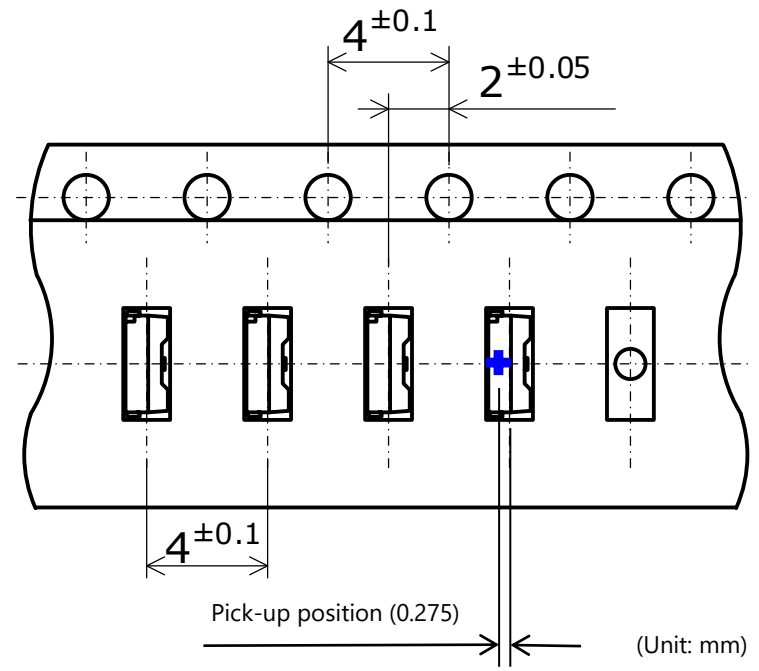

Figure 4. LED Pick-up Position in the Embossed Carrier Tape Pocket

4-2. Tape-and-Reel Feeder

- It is **recommended** to remove the top cover tape at a point sufficiently far away from the LED pick-up position.

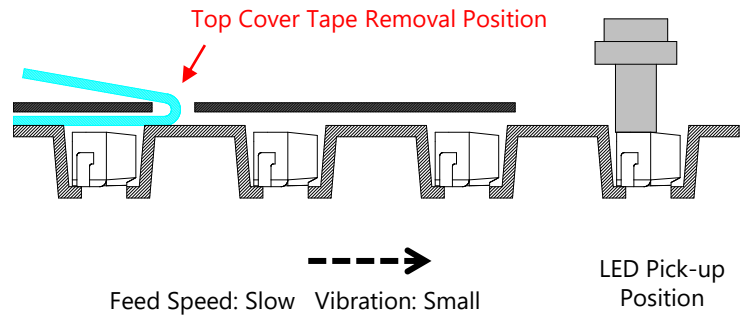

Figure 5. Top Cover Tape Removal Position

1. For the tape-and-reel feeder, the tape width is set to 12mm and the feeder pitch is set to 4mm.
2. Use a tape-and-reel feeder that ensures it does not create excessive vibrations causing assembly issues (e.g. an electrical [motorized] feeder).
 - When the tape feeder feed rate is fast, the LEDs in the embossed carrier tape pockets may not be in the correct position when picked by the nozzle; it may be improved by reducing the tape feeder feed rate.
3. It is recommended to remove the top cover tape at a point sufficiently far away from the LED pick-up position.

4-3. Recommended Nozzle Height for Pick-up Operations

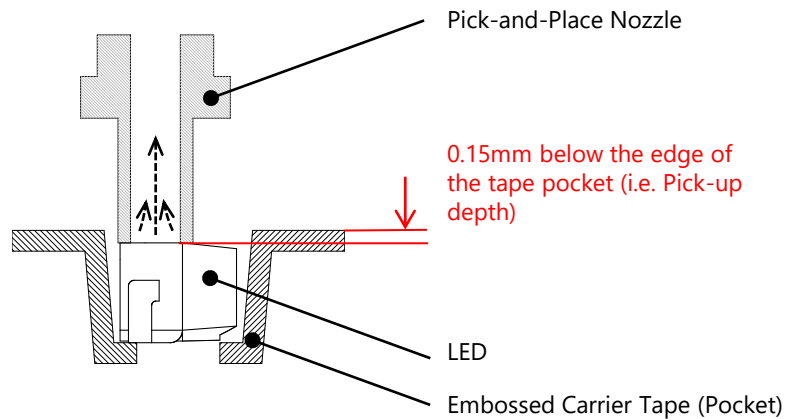

Figure 6. Recommended Nozzle Height for Pick-up Operations

4-4. Recommended Nozzle Height for Placement Operations (Placement Depth)

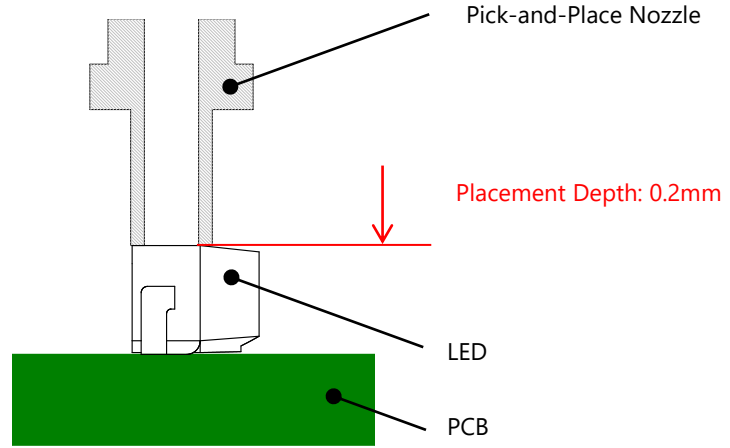

Figure 7. Recommended Nozzle Height for Placement Operations (Placement Depth)

1. Ensure that the nozzle goes down onto the LED in the tape pocket until the tip touches the flat surface of the LED.
Pick-up depth: 0.15mm
Note: If the reference level for the nozzle setting is at the edge of the tape pocket.
2. The recommended nozzle height for pick-up operations has been determined by Nichia under the verification conditions and may not function as expected with some other pick-and-place machines. If the pick-up operations are unstable even with using the recommended nozzle height, adjust the nozzle height appropriate for the pick-and-place machine being used.
 - If the pick point of the nozzle is too high,
 - it may cause insufficient suction power leading to picking errors (e.g. the nozzle's failure to pick/lift the LED into the air, incorrect picking causing the LED to tilt when in the air).
 - If the pick point of the nozzle is too low,
 - it may cause issues (e.g. causing the embossed carrier tape to shake, causing the tape pocket to deform) leading to picking failure.
1. The nozzle should further press the LED 0.2mm onto the PCB from the height where the LED first touches solder paste.
 - If the release point of the nozzle is too high,
 - it may cause placement issues (e.g. the LED to stick to the nozzle after placement, the LED to be mounted in an incorrect place/rotated position, the LED to become soldered to the PCB in a tilted position, etc.).
 - If the release point of the nozzle is too low,
 - excessive forces may be applied to the LED during placement and it may cause the LED to become damaged.

This document contains tentative information, Nichia may change the contents without notice.

4-5. Imaging-based Automatic Inspection

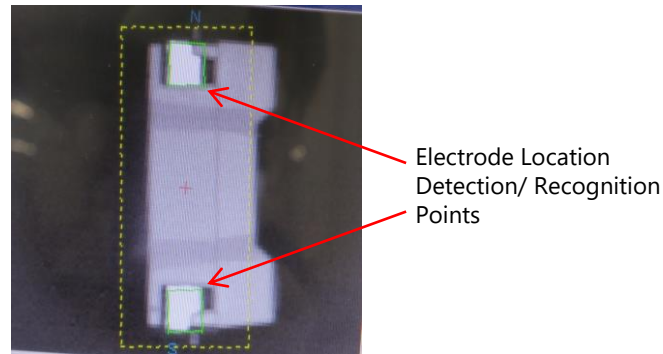

Figure 8. Recommended Reference Points to Detect, Recognize, or Locate the Electrodes

1. Nichia recommends using the electrodes as a reference to locate the center of the LED.
2. If the imaging device has trouble detecting/recognizing the electrodes, adjust the settings (i.e. the brightness of the light, etc.) of the pick-and-place machine.

5. Precautions When Reflow Soldering

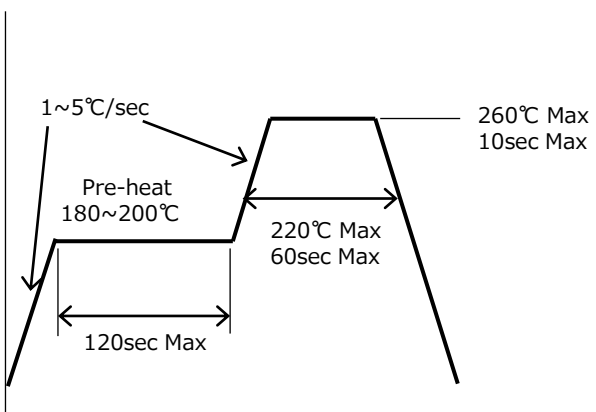

Figure 9. Recommended Reflow Soldering Condition (Lead-free Solder)

1. Reflow soldering must not be performed more than twice.
2. Nichia recommends using the reflow soldering conditions detailed in Figure 9 to the left; use the recommended reflow conditions specified by the manufacturer of the solder paste being used if it works better for the chosen application.

Note: To ensure that these reflow conditions have no negative effect on the LEDs, perform sufficient verification prior to use.

3. When cooling the LEDs from the peak temperature a gradual cooling slope is recommended; do not cool the LEDs rapidly.
4. During reflow soldering, the heat and atmosphere in the reflow oven may cause the optical characteristics to degrade. In particular, reflow soldering performed with an air atmosphere may have a greater negative effect on the optical characteristics than if a nitrogen atmosphere is used; Nichia recommends using a nitrogen reflow atmosphere.

This document contains tentative information, Nichia may change the contents without notice.

Disclaimer

This application note is a controlled document of Nichia Corporation (Nichia) published to provide technical information/data for reference purposes only. By using this application note, the user agrees to the following:

- This application note has been prepared solely for reference on the subject matters incorporated within it and Nichia makes no guarantee that customers will see the same results for their chosen application.
- The information/data contained herein are only typical examples of performances and/or applications for the product. Nichia does not provide any guarantees or grant any license under or immunity from any intellectual property rights or other rights held by Nichia or third parties.
- Nichia makes no representation or warranty, express or implied, as to the accuracy, completeness or usefulness of any information contained herein. In addition, Nichia shall not be liable for any damages or losses arising out of exploiting, using, or downloading or otherwise this document, or any other acts associated with this document.
- The content of this application note may be changed without any prior or subsequent notice.
- Copyrights and all other rights regarding the content of this document are reserved by Nichia or the right holders who have permitted Nichia to use the content. Without prior written consent of Nichia, republication, reproduction, and/or redistribution of the content of this document in any form or by any means, whether in whole or in part, including modifications or derivative works hereof, is strictly prohibited.

NICHIA CORPORATION 491 Oka, Kaminaka-Cho, Anan-Shi,
TOKUSHIMA 774-8601, JAPAN
<http://www.nichia.co.jp> Phone: +81-884-22-2311 Fax: +81-884-21-0148

This document contains tentative information, Nichia may change the contents without notice.